

Twin-lane high speed forming, cutting and wrapping machine for products in different wrapping styles. Simultaneous cutting and wrapping of products in twin-lane execution enables efficient and reliable high-performance wrapping of mass production.

U1-DCW

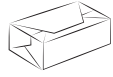

Envelope Fold



Bottom Fold



Side Fold

Products

- Hard and Soft Caramels
- Toffees
- Chewy Sweets
- Chewing Gum

Output

- up to 2000 products/min

Product dimensions



envelope fold:
Length: 30–35 mm
side fold, bottom fold:
Length: 16–38 mm
Width: 12–25 mm
Height: 4–15 mm
Special sizes upon
request



U1-DCW

Wrapping material

- Wax paper
- Cellophane
- Aluminium/paper – coated

Material dimensions

- Reel diameter: up to 350 mm
- Core diameter: 70–76,2 mm

Utilities

- Connected load: 12 kVA
- Compressed air consumption:
1,5 m³/h; 600 kPa
- Cooling water consumption:
0,15 m³/h
Temperature: 10 ... 15°C
Pressure: min. 200 kPa

Measurements

- Machine:
Length: 1900 mm
Width: 1800 mm
Height: 2200 mm
- Switch cabinet:
Length: 1200 mm
Width: 500 mm
Height: 2100 mm

Weight

- Machine: 1750 kg
- Switch cabinet: 250 kg

Combination

Depending on the product, the machine can be synchronized either with a batch roller and rope sizing machine (toffees, hard and soft caramels) or an appropriate extruder and cooling tunnel (chewing gum, bubble-gum, chewy candy).

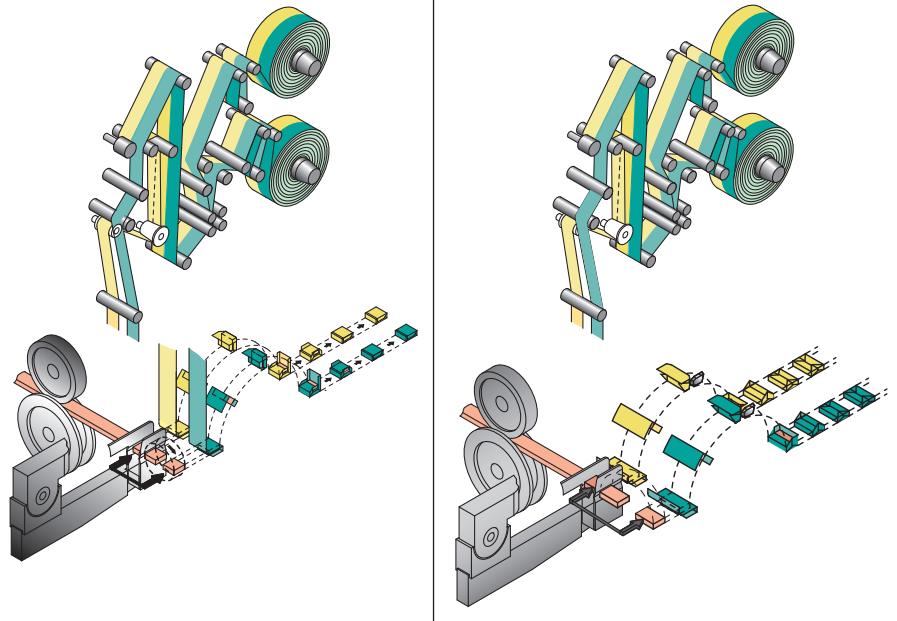

Special features

- two pieces are cut simultaneously by means of a double knife, wrapped in a dual track wrapping head and sealed in twin-lane discharge
- prefeeder and water-cooled guillotine knife
- Automatic splicer to change wrapping material reels without stopping the machine
- Servo control with PLC functions
- Central lubrication of all gear parts including oil pressure control/temperature control
- Pneumatic core locking and reel tensioning devices
- Servo-driven wrapping material feed rollers and wrapping material knife
- Reels of double width are split on the centreline
- All electrical and electronic components are located in a separate switch cabinet

- Excellent accessibility for operation, maintenance and cleaning purposes
- Easy operation due to the touch screen
- Due to the automatic operation, several machines can be handled by one operator
- System of protection: IP 54

Options

- Electronic speed control
- Photo-electric print registration
- sealing unit for the longitudinal seam and cooling section
- Ejecting unit for unwrapped products