

High speed plant to form, cut and wrap products in fold wrap with simultaneous overwrapping in flat stick packs or stick packs “on edge”.

# U1 + F1



Bottom Fold  
Primary packaging



Side Fold  
Primary packaging

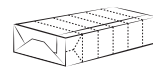

Stick Pack on edge  
Secondary packaging

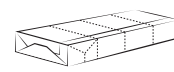

Stick Pack flat  
Secondary packaging

## Products

- Hard and Soft Caramels
- Toffees
- Chewy Sweets
- Chewing Gum

## Output

- up to 1000 single products/min
- up to 200 stick packs/min

## Product dimensions



**U1:**  
Length: 16– 45 mm  
Width: 12– 25 mm  
Height: 4– 15 mm



**F1:**  
Length: 25–113 mm  
Width: 15– 30 mm  
Height: 5– 25 mm  
Special sizes upon request.

Products per Stick Pack:  
Stick Pack flat  
2 – 8 pieces  
Stick Pack “on edge”:  
3 – 16 pieces

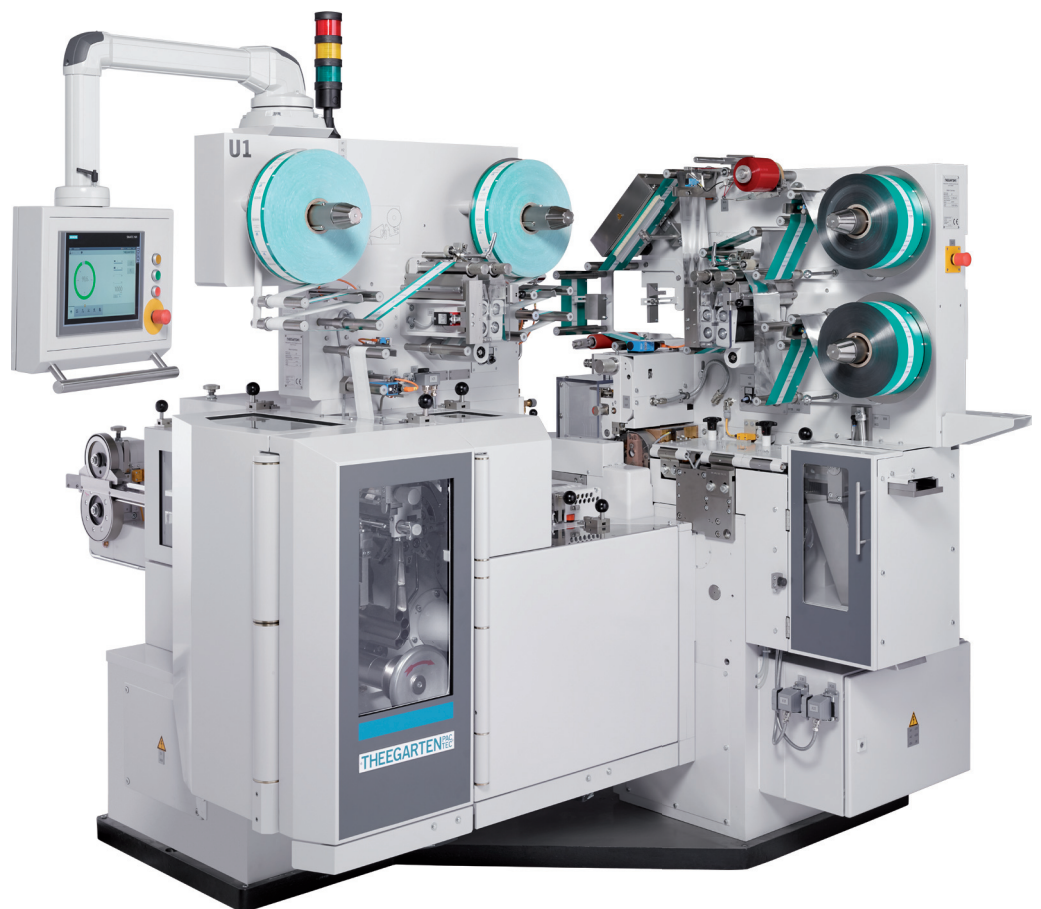

# U1 + F1

## Wrapping material

- All common wrapping materials can be used

## Material dimensions

- U1:
  - Reel diameter: up to 350 mm
  - Core diameter: 70–76,2 mm
- F1:
  - Reel diameter: up to 300 mm
  - Core diameter: 70–76,2 mm
- Tear tape:
  - Reel diameter: up to 120 mm
  - Reel width: up to 100 mm
  - Core diameter: 29 mm

## Utilities

- Connected load: 12 kVA
- Compressed air consumption: 1,5 m<sup>3</sup>/h; 600 kPa
- Cooling water consumption: 0,15 m<sup>3</sup>/h
- Temperature: 10 ... 15°C
- Pressure: min. 200 kPa

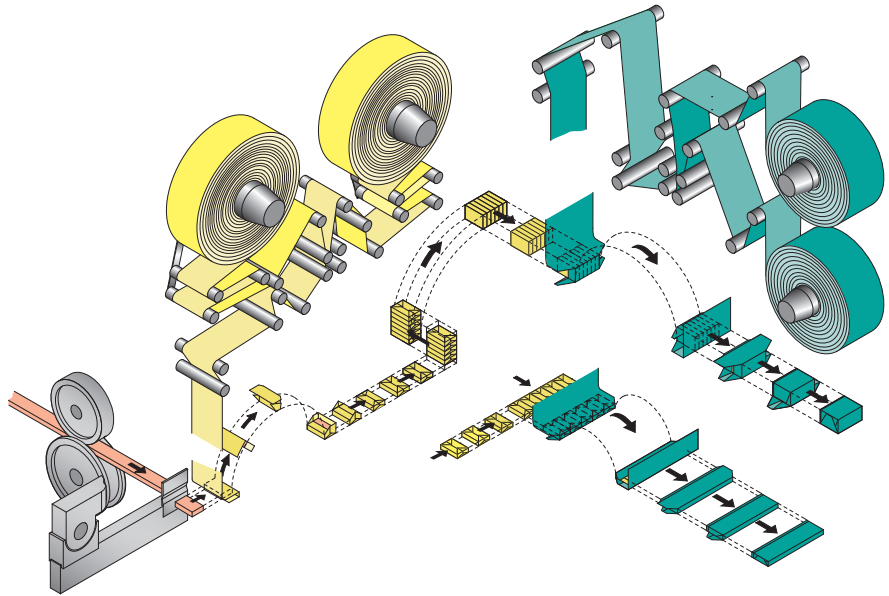

## Measurements

- Machine:
  - Length: 2420 mm
  - Width: 2020 mm
  - Height: 2040 mm
- Switch cabinet:
  - Length: 1800 mm
  - Width: 500 mm
  - Height: 2000 mm

## Weight

- Machine: 4500 kg
- Switch cabinet: 300 kg

## Combination

Depending on the product, the machine can be synchronized either with a batch roller and rope sizing machine (toffees, hard and soft caramels) or an appropriate extruder and cooling tunnel (chewing gum, bubble-gum, chewy candy).

## Special features

- cutting and wrapping of products in fold wrap with simultaneous overwrapping in stick packs
- prefeeder and water-cooled guillotine knife
- Automatic splicer to change wrapping material reels without stopping the machine
- Servo control with PLC functions
- Central lubrication of all gear parts including oil pressure control/temperature control
- Pneumatic core locking and reel tensioning devices
- Servo-driven wrapping material feed rollers and wrapping material knife
- Automatic temperature control of the sealing units
- All electrical and electronic components are located in a separate common switch cabinet
- Excellent accessibility for operation, maintenance and cleaning purposes
- Easy operation due to the touch screen
- Depending on local conditions, one operator is required
- System of protection: IP 54

## F1

- Photo-electric print registration
- Opening of the heat sealing units at machine stop
- Tear tape device

## Options

- Electronic speed control
- Possibility of conversion of the U1 machine to double twist wrap (can also be retrofitted)
- Special paper feed unit for U1 machine in case 2 wrapping materials (outer wrapper and under strip) are used – with or without automatic splicer for the outer wrapper
- Photo-electric print registration for individual products
- Turning respectively turn-up device (180°) for stick packs at the discharge of the F1
- Code dating device for stick packs
- Discharge unit for mal-registered respectively “spliced” stick packs for F1