

Compact and flexible wrapping machine for chocolate products.  
The modular design enables the processing of different products  
and wrapping styles on one machine.

# CWM2



## Products

- Deposited Chocolate Products
- Enrobed Chocolate Products  
(wafers, biscuits, cereals)

## Output

- up to 500 products/min  
Double Twist
- up to 400 products/min  
Bunch and Envelope Fold
- up to 350 products/min  
Top Twist, Side Twist,  
and Protected Twist



## Product dimensions



Double Twist/  
Protected Twist/  
Bunch:  
Length: 16–60 mm  
Width: 15–40 mm  
Height: 8–28 mm  
Top Twist:  
Length: 20–28 mm  
Width: 18–28 mm  
Height: 15–28 mm  
Side Twist:  
Length: 18–40 mm  
Width: 15–35 mm  
Height: 8–30 mm  
Envelope Fold:  
Length: 18–60 mm  
controlled discharge:  
18–40 mm  
Width: 15–40 mm  
Height: 8–28 mm



Double Twist/  
Protected Twist/  
Bunch:  
Ø: 18–35 mm  
Height: 8–28 mm  
Top Twist:  
Ø: 22–35 mm  
Height: 15–28 mm  
Side Twist:  
Ø: 18–35 mm  
Height: 8–30 mm



Double Twist:  
Ø: 18–35 mm

# CWM2

## Wrapping material

- Wax paper
- Cellophane
- Polypropylene
- Aluminium foil

## Material dimensions

- Reel diameter: up to 350 mm
- Reel width: up to 150 mm
- Core diameter: 70–79 mm

## Utilities

- Connected load: 11 kVA
- Compressed air consumption:  
1 m<sup>3</sup>/h; 600 kPa

## Measurements

- Machine:
  - Length: 3650 mm
  - Width: 1900 mm
  - Height: 1960 mm

## Weight

- Machine: 2200 kg

## Combination

Beside manual feeding, the machine can be directly synchronized to the production line by means of a Theegarten-Pactec belt feeding or robotic pick and place system.

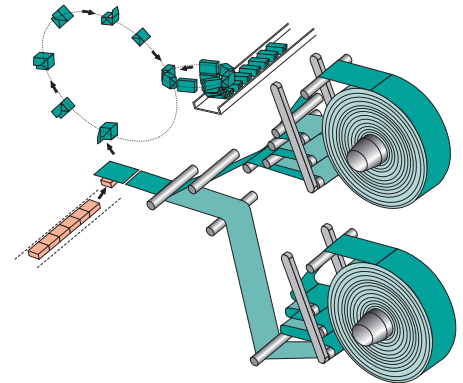
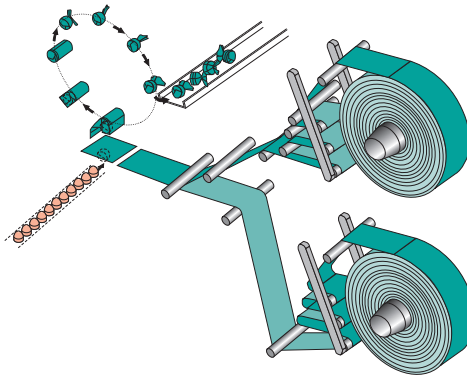

## Special features

- Electronically controlled, servo driven infeed module for single lane product accumulation and synchronization
- Accumulation belt to accumulate the products
- Vacuum supported phasing belt to synchronize the products to the machine cycle
- Inline transfer of the products to the pickup position
- Feeding system controlled by laser sensors to adopt machine speed to the product accumulation level
- Two reel holders for the wrapping material with mechanical core locking devices
- Servo motor driven wrapping material reels
- Servo motor driven wrapping material draw off roller to control cut off length and adopt photo-electrical print registration signals
- Servo motor driven wrapping material knife with carbon steel insert for a precise cut and an extended service life
- Automatic splicer to change wrapping material reels without stopping the machine
- Saving of wrapping material by “no product – no paper”-device
- Discharge chute for wrapped products
- Ejection of spliced, mal-registered and unwrapped products

## Options

- Modular machine design in order to facilitate the change of wrapping style and/or product dimensions
- Accordingly to the requirements of the products, the feeding system is designed as robotic system with lug chain or as belt feeding system
- Additional reel holders for a second wrapping material (under strip)
- with automatic splicer
- Wrapping material feed for inner and outer wrapping material with optional displacement of the inner wrapper to guarantee a high wrapping quality
- Pneumatic core locking and reel tensioning devices
- Photo-electric print registration
- Defined product discharge
- Glue applicator for tag glue product closure
- Remote diagnostics