

Dual track high speed wrapping machine for chocolate products in envelope fold. Simultaneous feeding and wrapping of products on two tracks enables efficient and reliable high-performance production.

CFW-D

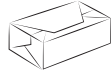

Envelope Fold



Envelope Fold
with Banderole

Products

- moulded chocolate products
- enrobed chocolate products
- wafers

Output

- up to 1400 products/min

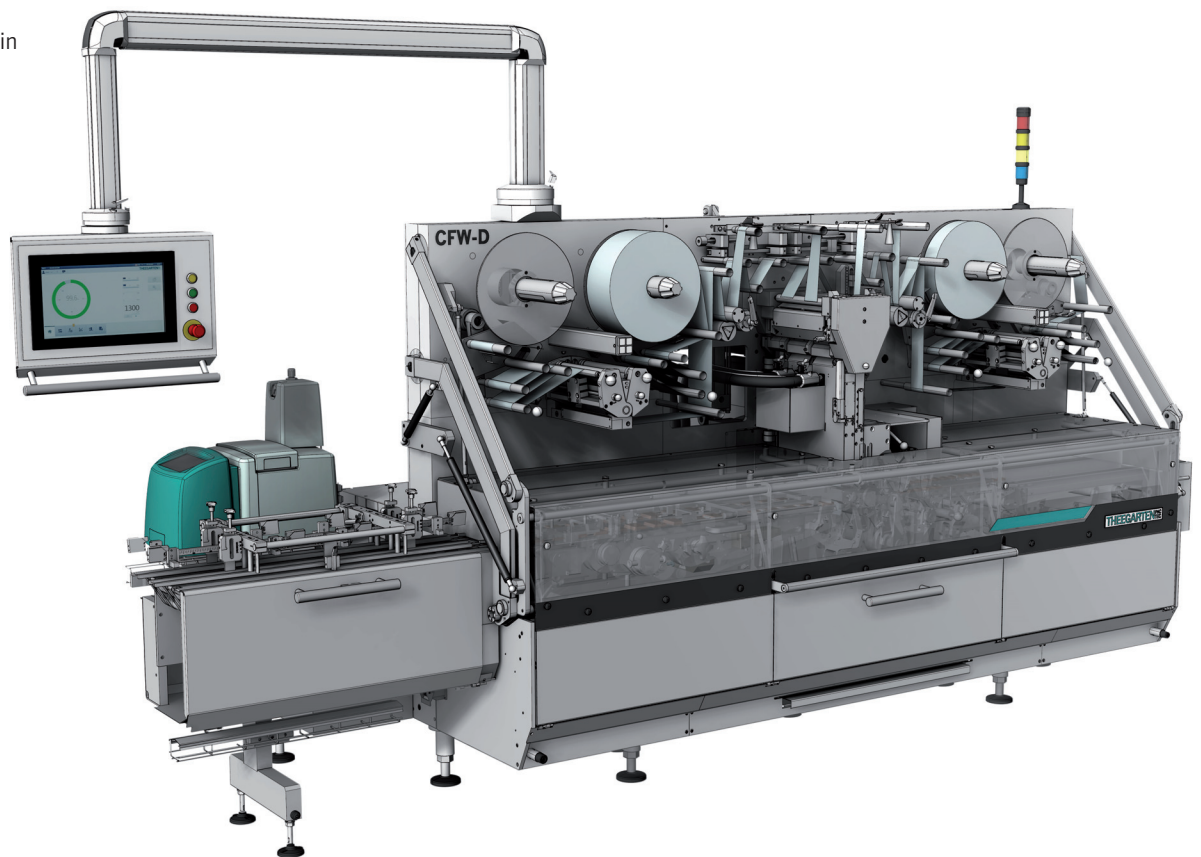

Product dimensions



Length:	25– 60 mm
Width:	15– 50 mm
Height:	5– 25 mm

CFW-D

Wrapping material

- Aluminium foil
- Aluminium laminates
- Polypropylene
- Paper (Banderole)

Material dimensions

- Reel diameter: up to 350 mm
- Core diameter: 70–76,2 mm

Utilities

- Connected load: 22 kVA
- Compressed air consumption:
1,5 m³/h; 600 kPa
- Cooling water consumption:
0,15 – 0,21m³/h
Temperature: 10 ... 15°C
Pressure: min. 200 kPa

Measurements

- Machine:
Length: 4122 mm
Width: 1343 mm
Height: 2490 mm
- Feeding unit:
Length: 3405 mm
Width: 780 mm
Height: 1100 mm
- Switch cabinet:
Length: 1800 mm
Width: 500 mm
Height: 2100 mm

Wrapping material speed

- Machine: 3000 kg
- Feeding unit: 600 kg
- Switch cabinet: 550 kg

Combination

By means of a dual track discharge unit a direct synchronization to the feeding unit is possible. A synchronization with down-stream overwrapping (cartoning or flow-pack machines) machines is also possible.

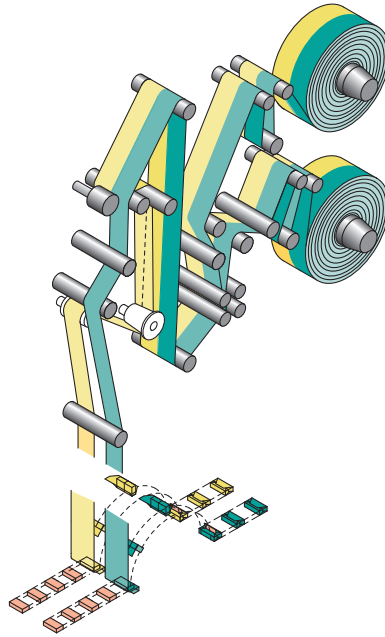

Special features

- Products are fed by a twin-lane feeding belt, wrapped in a dual track wrapping head and sealed in twin-lane discharge
- Electronically controlled product feed
- A continuous transport of the products is achieved by precisely synchronised conveying speeds of the feeding conveyors. This guarantees that delicate products are almost not exposed to any accumulation pressure.
- A particularly gentle handling of the products is guaranteed by overlapping conveyor stages – no roller edges between the conveyor stages
- Spring retainer jaws within the packing head compensate product tolerances
- Wrapping material reels of double width are split on the centreline
- Automatic splicer to change wrapping material reels without stopping the machine
- Ejection of spliced, mal-registered and unwrapped products
- Pneumatic core locking and reel tensioning devices
- Servo-driven wrapping material feed rollers and wrapping material knife
- Air support to allow the use of PP foils
- Servo control with PLC functions
- Central lubrication of all gear parts including oil pressure control

- All electrical and electronic components are located in a separate switch cabinet
- Excellent accessibility for operation, maintenance and cleaning purposes
- Easy operation due to the touch screen
- Due to the automatic operation, several machines can be handled by one operator

Options

- Photo-electric print registration
- Additional reel holders for a second wrapping material (banderole or under strip) with automatic splicer
- Gluing device for the application of one or two glue dots for product closure